



Translucent Roofing Catalogue







Laserlite Building Products is an internationally recognised and respected roofing product manufacturer, having purchased Galaxy Rooflite in January 2020. Topglass® GC is also manufactured in Hamilton, New Zealand from our Alsynite One facility.

As new sheeting product development is an integral part of the company's business, Laserlite Building Products remain at the cutting edge, offering local and international customers state-of-the-art manufacturing equipment and processes designed to remain at the forefront of the GRP composites industry. Computerised automated production lines with advanced forming and curing techniques produce high clarity and solid panel products of all grades.

Laserlite Building Products is JAZ-ANZ accredited under the Benchmark Certification scheme. Recognised in more than 90 countries and providing security and respect to our customers JAZ-ANZ accreditation not only guarantees accurate systems processes but also ensures consistent and monitored product legally certified to AS 4256.3:2006.

Laserlite Building Products brands include the Laserlite® Polycarbonate Roofing range, Topglass® GRP Sheeting, Industrial turbine rotary ventilators and an extensive range of fastenings and roofing accessories. These products and an extensive range of roofing accessories ensures Laserlite Building Products continues to meet ongoing customer requirements.



 Topglass®	UV Stabilised Commercial Grade Reinforced Translucent Roofing	4-5
 Topglass® GC	Gel-Coated Translucent Roofing	6-7
 Topglass® FR50	Fire Retardant Translucent Roofing	8
 TopCool	High impact, Corrosion Resistant Glass Reinforced Translucent Roofing	9
 Topglass® GC Ultra-Safe	Heat Reducing Fibre Reinforced Translucent Roofing	10-11
 Topglass® GC SPF	Solar Protective Gel-Coated Translucent Roofing	12-13
 Twinskin Systems	Heat Reducing Translucent Roofing	14-15
 Triple Skin Systems	Translucent Roofing	16
Technical Information		17
Installation Instructions		18-19
Panel Testing		20-21



Introduction

Topglass® translucent roofing has been specifically developed to combat the effect of ultra-violet rays and atmospheric pollutants without the yellowing and rapid product degradation associated with commonly available glass reinforced roof sheeting. Utilising major technological advances developed by both Laserlite Building Products and its suppliers, Topglass® is supplied as a cost-effective product encompassing a purpose developed UV stabilised composite resin system.

Key Benefits

- Topglass® is manufactured from an acrylic modified resin system, reinforced with high quality glass fibre rovings
- Topglass® utilises surface coatings which are especially formulated and designed to provide high quality long term natural light transmission
- Topglass® encompasses in-built NZA-5 UV inhibitors which prevent early degradation, yellowing and embrittlement of the sheet
- The product is oven cured and profiled to ensure maximum binding and strength
- The non-porous weather surface prevents water absorption and osmosis
- Reduced fibre show in comparison to standard commercial grade translucent roofing products
- The weather surface retains its smooth finish for a greater period of time providing self-cleaning benefits
- An extremely flexible product providing innovative product variations in meeting design criteria
- Topglass® is extremely cost effective UV resistant translucent roof sheeting

Applications

- Commercial, industrial, institutional and other projects where long-term high quality lighting is required
- School/Kindergarten and public outdoor areas requiring excellent UV protection

Special Applications

- Topglass® can be supplied encompassing a purpose developed corrosive resistant resin for use in areas of extreme corrosion
- All Topglass® products can be supplied in various Twinskin Systems providing excellent thermal/acoustic benefits and energy savings
- Topglass® can be provided as TopCool to reduce light and heat transmission. This is recommended due to the long term clarity of the sheet
- Topglass® roofing profiles can be supplied in reduced width sheet if so required

Surface Coatings

The Topglass® weather surface polyester coating incorporates UV inhibitors and offers protection against early yellowing and degradation of the sheet. In specific applications and where minor corrosion may affect the underside of the sheeting, Laserlite Building Products Topglass® GC can be supplied in place of the standard polyester film.

Colours and Tints

Topglass® is available in standard colours of Clear, Opal and TopCool. Other colours to suit specific design criteria are available on request. Minimum order quantities may apply for non-standard colours.

Operating Temperature

The operating temperature range of Topglass® is - 40° to +110° C.

Fire Retardant

Topglass® can be supplied as fire retardant sheeting. See Topglass® FR50

Safety

To comply with the requirements of AS 1562.3: 2006 Part 3 Plastic, translucent roofing products are classified as “Brittle Roofing” and therefore not suitable to support foot traffic. With the exception of Topglass® GC Ultra-Safe. Safety mesh should be installed under all translucent roofing.

Specification

The Translucent roofing shall be Topglass® reinforced polyester roof sheeting as manufactured by Laserlite Building Products to comply with AS 4256.3: 2006 JAS-ANZ Certification Licence No. 2349.

The sheeting shall be measured in g/m² or mm (sheet thickness) and manufactured to conform to the nominated roofing and cladding profile. Installation shall be carried out in accordance with the requirements of AS 1562.3: 2006.

Warranty

Topglass® incorporates UV Stabilised film, providing a 10 Year Warranty. Terms and Conditions apply.

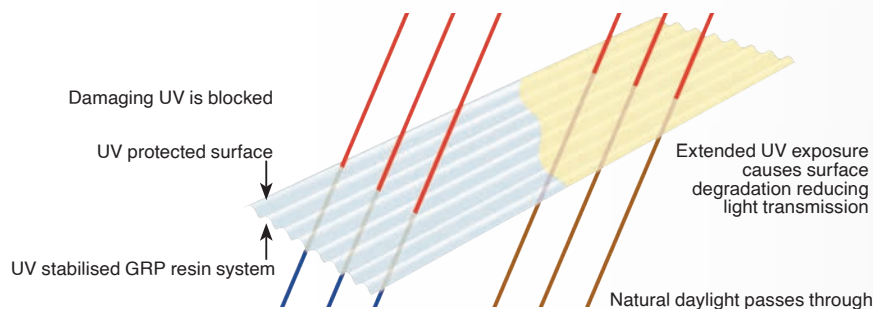

Light and Solar transmission information is issued as a guide only and based on interpretation of natural exposure testing. Full test information is available from Laserlite Building Products. Topglass® Solar, Optical and Ultra Violet

Weight	Colour					
	Clear		Opal		TopCool	
	Light	Solar	Light	Solar	Light	Solar
2400g/m ² (1.5mm)	74%	65%	58%	49%	33%	22%
3660g/m ² (2.5mm)	62%	58%	47%	40%	n/a	n/a

*Topglass® TopCool provides blocking of 99.9% UVA and 100% UVB harmful Ultra Violet Light.	
Solar heat gain	227w/m ²
Shading co-efficient	.33
Solar heat gain co-efficient	0.20
UVA transmittance	.1%
UVB transmittance	0.0%

Compare the discolouration of sheeting after accelerated weathering

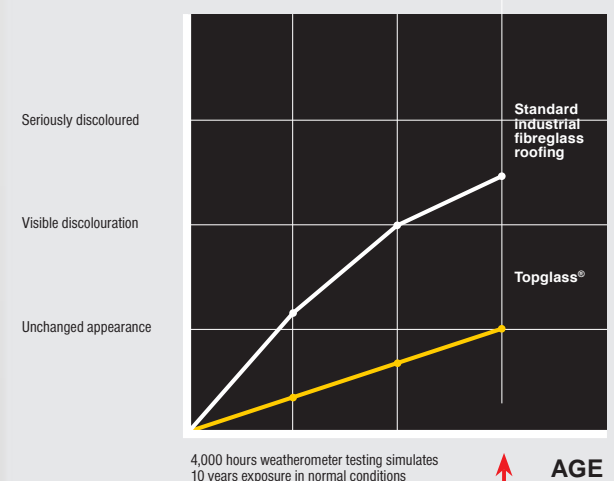

Topglass® out-performs conventional fibreglass materials. Topglass® retains light transmission and discolouration resistance after 4,000 hours continuous UV exposure (equivalent to 10 years in 'normal' conditions).



Introduction

Topglass® GC is the flagship of the Topglass® natural lighting family of products, and uses an innovative manufacturing process developed by Laserlite Building Products, whereby a 100 micron* EXO-SET 206 Premium Gelcoat is applied to the weather surface of the sheeting.

Offering exceptional resistance against corrosive atmospheres and providing protection against solar deterioration, Topglass® GC brings additional benefits to building designers and owners. Topglass® GC can also be supplied in solid colours providing an excellent alternative to metal roofing and cladding systems in corrosive environments.

Key Benefits

- Manufactured from an acrylic modified polyester resin system and incorporating additional ultra violet stabilisers, Topglass® GC utilises antistatic high-quality glass fibre rovings to give maximum strength during the curing and bonding process
- The ultimate benefit of the Topglass® GC product over general purpose grades of GRP, natural roof lighting products is the addition of Laserlite Building Products' UV-stabilised 100 micron* EXO-SET 206 Gelcoat surface which is a reactive thermo-set to provide a high gloss surface
- Topglass® GC, which is manufactured to meet the requirements of AS 4256:3.2006, is economical and provides flexibility whilst resisting UV degradation and yellowing much longer than is commonly experienced with general purpose grade translucent roofing products
- Harmful UV Rays remain a major concern for today's building designers. Topglass® GC can be supplied in a variety of pigments and can be supplied as Topglass® GC SPF. This innovative Gelcoat additive provides excellent UVA and UVB block and offers exceptional heat and light data

Applications

- Roof and wall lighting to all commercial, industrial, institutional and other buildings requiring long term natural lighting without early surface degradation
- School/Childcare Centres and public outdoor areas requiring good UV protection

Special Applications

- Topglass® GC can be pigmented to meet varying light and solar transmission requirements;
- Heavy-duty solid colour-fast roofing and cladding can be supplied to replace traditional roofing and cladding products for use where corrosion exists.

Surface Coatings

- The Laserlite Building Products 100 micron* EXO-SET 206 Premium Gelcoat weather surface used in the manufacture of Topglass® GC gives very good protection against solar deterioration. The reverse side of the sheeting is protected with a 20 micron UV stabilised Polyester film. Where corrosive atmospheres exist which affect the underside of the sheeting, Laserlite Building Products Topglass® GC can be supplied in place of the film.



100 MICRON* EXO-SET
GEL-COAT WEATHER
SURFACE

UV STABILISED
NON-DELAMINATING
CARRIER FILM

* Nominal Thickness 100 Micron.



Colours and Tints

Topglass® GC is available in standard colours of Clear, Opal and TopCool. Other colours to suit specific design criteria are available on request. MOQ may apply for non-standard colours.

Operating Temperature

The operating temperature of Topglass® GC is -30°C to + 70°C.

Noise Reducing Sheeting

Topglass® GC can be supplied as an effective noise-reducing sheeting. See: Topglass® Twinskin Systems and Triple Skin Systems.

Fire Retardant

Topglass® GC can be supplied as fire retardant sheeting. See Topglass® FR50.

Safety

To comply with the requirements of AS 1562.3: 2006 Part 3 Plastic, translucent roofing products are classified as “Brittle Roofing” and therefore not suitable to support foot traffic. With exception of Topglass® GC Ultra-Safe. Safety mesh should be installed under all translucent roofing.

Severe Corrosion Environments

In areas where corrosion is severe, Topglass® GC can be manufactured using a special purpose Vinyl Ester corrosion-resistant resin system.

Specification

The Translucent roofing shall be Topglass® GC reinforced Polyester roof sheeting as manufactured by Laserlite Building Products to comply with AS 4256.3: 2006 JAS-ANZ Certification Licence No. 2349. The sheeting is measured in g/m² or mm (sheet thickness) and manufactured to conform to the nominated roofing and cladding profile. Installation shall be carried out in accordance with the requirements of AS 1562.3: 2006.

Warranty

25 Year Warranty. Terms and Conditions apply.

Visible Light and Solar Transmission						
Weight	Colour					
	Clear		Opal		TopCool	
	Light	Solar	Light	Solar	Light	Solar
2400g/m ² (1.5mm)	74%	65%	58%	49%	33%	22%
3660g/m ² (2.5mm)	62%	58%	47%	40%	n/a	n/a

Light and Solar transmission information is issued as a guide only and based on interpretation of natural exposure testing.



Introduction

Topglass® FR50 is designed and supplied as a fire and smoke retardant natural lighting system for use in commercial and industrial buildings. This type of resin system alters the flammability point of the sheeting; however it should be noted Laserlite Building Products supplies all GRP sheeting in this brochure as natural lighting/cladding products only.

Key Benefits

- Specifically formulated using fire retardant materials for use in commercial building applications and educational institutions.
- Can be considered into building designs that specifically require reduced ignitability, flame propagation and heat and smoke release over conventional resin systems.

Applications

- Schools and educational institutions
- Public assembly areas
- Combustible areas with high fire risk
- Where egress from a building in the event of fire may be restrictive

Special Applications

BRANZ test report FH 4937 October 2012 contained in this literature refers to Topglass® FR50. Contact Laserlite Building Products for advice on more advanced fire and smoke retardant resin systems.

Surface Coatings

Topglass® FR50 is supplied with the Laserlite Building Products 100 micron* Exo-Set 206 SPF enhanced Gelcoat system. It is supplied as a translucent roofing product and is available with increased solar values with the addition of Topglass® TopCool. The SPF enhancement stabilises the product, offering increased weather surface stability in colour retention.

Colours and Tints

Available in Opal, Clear and TopCool.

Safety

To comply with the requirements of AS 1562.3: 2006 Part 3 Plastic, translucent roofing products are classified as “Brittle Roofing” and therefore not suitable to support foot traffic. With exception of Topglass® GC Ultra-Safe. Safety mesh should be installed under all translucent roofing.

Specification

The Translucent roofing shall be Topglass® FR50 reinforced Polyester roof sheeting as manufactured by Laserlite Building Products to comply with AS 4256.3: 2006 JAS-ANZ Certification Licence No. 2349. The sheeting shall be measured in g/m² or mm (sheet thickness) and manufactured to conform to the nominated roofing and cladding profile. Installation shall be carried out in accordance with the requirements of AS 1562.3: 2006.

Quality and Testing 7-543772-CN*		
Ignitability Index	15	Range 0 - 20
Spread of Flame	7	Range 0 - 10
Heat Evolved Index	7	Range 0 - 10
Smoke Developed	8	Range 0 - 10

*When tested in accordance with AS 1530.3 - 1999



Introduction

Laserlite Building Products' TopCool is a specialised heat-reducing fibre-reinforced polyester sheeting, designed for industrial, commercial and domestic applications where maximum light transmission with minimal heat transfer is desirable. This product is produced using premium quality raw materials with the latest nanotechnology resins and surface films.

Laserlite Building Products' TopCool contributes to providing a comfortable environment, and will help reduce energy costs associated with air conditioning and artificial lighting.

Key Benefits

- Nanosphere technology
- Provides substantial savings in energy costs
- Superior long-term reduction of solar heat transfer
- Excellent long-term weathering characteristics
- Superior long-term diffused light properties

Applications

- Industrial and commercial skylights
- Building skylight sidings
- Nursery and retail areas
- Sports venue skylights
- Light diffuser
- Non-delaminating surface technology
- Resistant to degradation and embrittlement
- Outstanding surface erosion resistance
- Resistant to commonplace chemicals

Colours and Tints

TopCool comes in one colour only, allowing a light transmission of 40% and a solar transmittance reduction of up to 52.5% from standard plastic sheeting. This is achieved by the fusion of white pigment, polyester resin and nanospheres prior to our unique curing process. This process promotes, superior heat reflecting properties and is a clean, aesthetically pleasing product that enhances even light distribution.

Visible Light and Solar Transmission						
Weight	Colour					
	Clear		Opal		TopCool	
	Light	Solar	Light	Solar	Light	Solar
2400g/m ² (1.5mm)	74%	65%	58%	49%	33%	22%
3660g/m ² (2.5mm)	62%	58%	47%	40%	n/a	n/a

*Topglass® TopCool provides blocking of 99.9% UVA and 100% UVB harmful Ultra Violet Light.

Solar heat gain	227w/m ²
Shading co-efficient	.33
Solar heat gain co-efficient	0.20
UVA transmittance	.1%
UVB transmittance	0.0%

*conditions apply

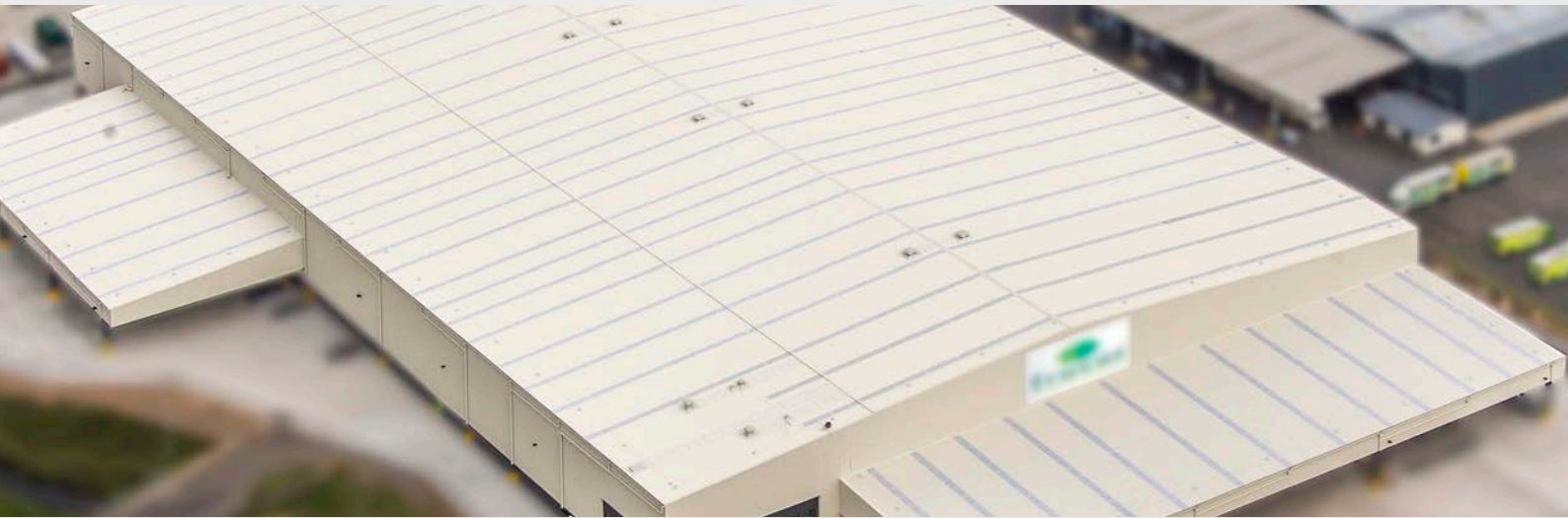

Introduction

Industry concerns relating to Natural Roof Lighting being classified as “brittle” and therefore possibly posing a danger to foot traffic on the roof, has led to Laserlite Building Products’ purpose-developing a heavy-duty and high-impact roof lighting system to alleviate these concerns. Aptly named Topglass® GC Ultra-Safe, the product utilises a heavy-duty, woven roving reinforcing system positioned within the resin matrix, providing exceptional strength.

Key Benefits

- Topglass® GC Ultra-Safe is manufactured utilising heavy-duty woven roving enclosed within the resin matrix which in turn provides a structural capability not normally available with traditional translucent roofing materials
- Topglass® GC Ultra-Safe meets the impact strength tests of AS/NZS 4040.4 and satisfies the requirements of AS 4256.3 alleviating the need for safety mesh to be installed under the sheeting (refer to Safety). This is of particular benefit to building designers who face corrosive atmospheres damaging the safety mesh zinc coating.
- As the roving matrix runs both longitudinally and laterally within the sheet, Topglass® GC Ultra-Safe demonstrates exceptional high impact strength
- Corrosion resistant when installed in wide range of aggressive environments
- Excellent spanning capabilities
- Topglass® GC Ultra-Safe meets the impact strength tests of AS 4256.3 clause 11.3, AS 4040.1, and AS 1562 alleviating the need for safety mesh, rather than just a roof lighting product

Applications

- Educational facilities and Public Assembly areas
- Fertiliser Plants
- Chemical and Powder-coating Plants
- Wool scouring facilities
- Waste water treatment plants
- Salt Extraction Facilities
- Severe marine environments
- Natural roof lighting where safety mesh is not installed
- Wood Pulp and Paper Plants

* Nominal Thickness 100 Micron.



Special Applications

- In severe corrosive environments, the Topglass® GC Ultra-Safe resin system can be fortified using Vinyl Ester to provide maximum protection.
- Topglass® GC Ultra-Safe can be supplied as a heavy duty solid coloured roofing and cladding material to replace metal roofing products for use in corrosive environments.

Weather Surface Coating

Laserlite Building Products 100 micron* EXO-SET 206 Premium Gelcoat weather surface used in the manufacture of Topglass® GC Ultra-Safe offers superior sheet clarity and unsurpassed long-term UV resistance against premature yellowing.

Weight/Thickness of Sheeting

Topglass® GC Ultra-Safe is supplied as standard weight of 3660g/m².

Colours

The standard colours of Topglass® GC Ultra-Safe are Clear, Opal and TopCool.

Safety

Whilst Topglass® GC Ultra-Safe is classified as heavy-duty, meets the impact test of AS 4040.4, satisfying the requirements of AS 4256.3, and can support foot traffic, long-term degradation and/or post roof installation impact damage can seriously affect the performance of the sheeting. In order to comply with the requirements of AS 1562.3:2006 Part 3 Plastic, protect the weather surface coating and provide continual structural strength, all FRP products should be protected from foot traffic, therefore a suitable proprietary aluminium walkway is always recommended. Consult Laserlite Building Products for recommended systems.

Specification

The translucent sheeting and/or roofing and cladding shall be Topglass® GC Ultra-Safe as manufactured by Laserlite Building Products to comply with AS 4256.3 JAS-ANZ Certification Licence No 2349. The sheeting shall conform to the nominated roofing and cladding profile and installed in accordance with the requirements of the Laserlite Building Products Topglass® GC Ultra-Safe proprietary safety fixing system.

Warranty

25 Year Warranty. Terms and Conditions apply.

Light and Solar Transmission		
Tint	Visible Light Transmission	Solar Transmission
Clear	61%	56%
Opal	58%	49%
TopCool	40%	22%

SOLAR PROTECTIVE GELCOATED TRANSLUCENT ROOFING

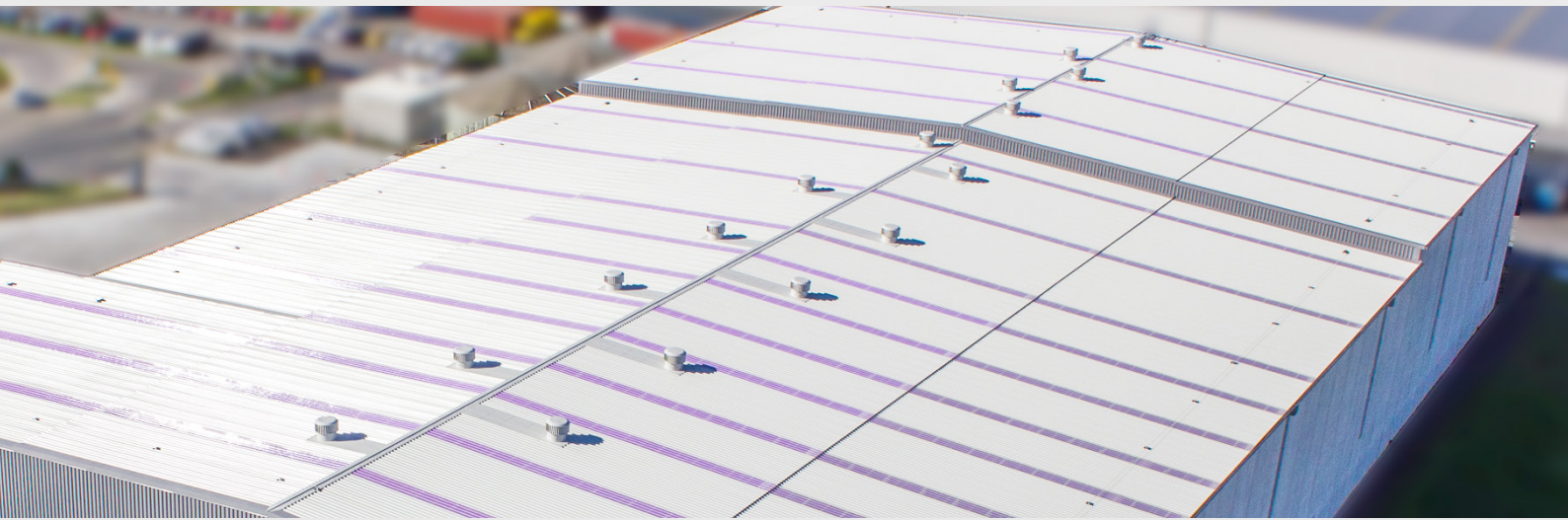

Introduction

A revolutionary and innovative Gelcoated natural lighting product developed using Laserlite Building Products Technology and aptly named Topglass® SPF (Solar Protection Feature). Encompassing a unique manufacturing process similar to that used in the design and manufacture of modern sunglass eyewear, Topglass® SPF Solar control roof lighting, selects and singles out infrared (heat) plus harmful ultraviolet rays, thereby preventing heat build-up and UV damage to Stock and Plant.

Key Benefits

- Provides maximum visible light transmission whilst preventing unwanted solar transmission into a building
- Reduces energy and air-conditioning costs along with the need for additional artificial lighting
- Virtually eliminates harmful UVA and UVB ultra violet rays from entering a building
- The sheet is aesthetically unique, providing innovative design characteristics for building designers
- Long-term effective light transmission
- Excellent project warranties
- Topglass® SPF is JAS-ANZ certified to AS 4256:3.2006 Licence No. 2349.

Applications

- Food manufacturing buildings
- Warehouses and retail outlets storing food and fresh produce
- Shopping centres and supermarkets
- Bulk paper stores
- Temperature-sensitive environments requiring high-quality, long-term natural lighting

Weather Surface Coating

Laserlite Building Products 100 micron* EXO-SET 206 Premium Gelcoat weather surface.

Product Variations

Product	Visible Light Transmission	Total Solar Transmission
Topglass® SPF 4	64%	50%
Topglass® SPF 8	49%	36%



Introduction

Where potential condensation issues are of concern, Laserlite Building Products manufacture a Twinskin System that offers a solution to this problem. Two independently formed sheets of Topglass® are laid over each other to form an effective air gap between the sheets. Condensation evaporates and this prevents water droplets entering the building. Laserlite Building Products Twinskin Systems also offers building occupants a reduced noise level from outside influences, as the system offers an effective acoustical reducing solution.

Key Benefits

- Manufactured from an acrylic modified resin system, reinforced with high quality glass fibre rovings.
- Reduces internal heat build-up and offers a passive natural lighting concept.
- Effective noise reducing system.
- Eliminates condensation in most applications.
- Manufactured and supplied to side-lap most current popular steel roofing profiles.
- Manufactured and supplied in one length as a complete system, ridge-to-gutter or ridge-to-step if a stepped roof.

Applications

Commercial, industrial, institutional sports stadiums and other projects where long term high quality natural lighting is required.

Special Applications

Laserlite Building Products Twinskin System can be supplied to meet varying light and solar transmission requirements to meet any design criteria.

Surface Coatings

Topglass® GC is the preferred choice for Twinskin Systems for the external weather surface. Laserlite Building Products 100 micron* EXO-SET 206 Gelcoat weather surface offers excellent protection against solar deterioration. A 20 micron film can be applied to the reverse side of the laminate or where corrosive atmospheres exist which may affect the underside of the sheeting. Laserlite Building Products Topglass TopCool® can be supplied.

Colours and Tints

Laserlite Building Products Twinskin Systems typically are supplied with a low pigment additive in the top sheet and a clear support under sheet. This configuration offers the building interior a soft passive environment without direct sunlight penetration. However any combination of pigment colours is readily available, consult Laserlite Building Products for pigment level recommendations.

Heat Reducing Sheeting

As an added barrier against solar heat build-up, Twinskin Systems can include SPF 4 and SPF 8 formulations.

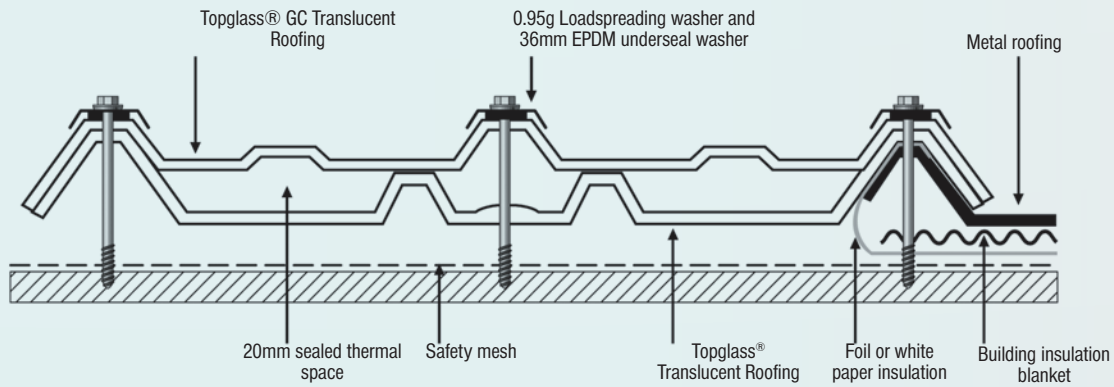

NOTE:
 • Gutter end sealed with purpose made Laserlite Building Products closed cell foam strip
 • Twinskin clear roofing at 2400g/m² (1.5mm thick) provides light transmission of 70%

Operating Temperature

Laserlite Building Products Twinskin Systems operating temperature is -30°C to +70°C

Fire Retardant

Laserlite Building Products Twinskin Systems operating temperature is -30°C to +70°C supplied as Topglass GC FR 50 Plus.

Laserlite Building Products Twinskin Systems can also be supplied as Topglass® FR50

Safety

To comply with the requirements of AS 1562.3:2006 Part 3 Plastic, translucent roofing products are classified as brittle roofing and therefore not suitable to support foot traffic – with the exception of Topglass® GC Ultra-Safe. Note that safety mesh should be installed under all translucent roofing.

Severe Corrosion Environments

In areas where corrosion is severe Twinskin Systems can be supplied with a vinyl ester resin system.

Specification

The translucent Twinskin System shall be Laserlite Building Products reinforced polyester roof sheeting manufactured by Laserlite Building Products to comply with AS4256.3:2006 JAZ-ANZ certification licence number 2349. The sheeting shall be measured in g/m² or mm (sheet thickness) and manufactured to conform to the nominated roofing and cladding profile. Insulated Translucent Roofing systems can be manufactured to meet building fire standard groups 3, 2 and 1-S classifications. Test report available from Laserlite Building Products. Installation shall be carried out in accordance with the requirements of AS 1562.3:2006.

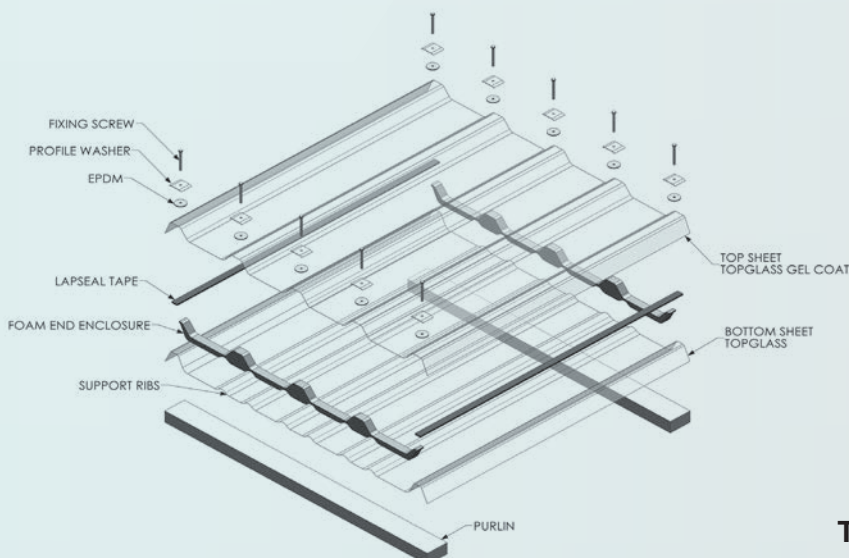

Twinskin Roofing System - Profile Exploded

TRANSLUCENT ROOFING

TRIPLE SKIN SYSTEM

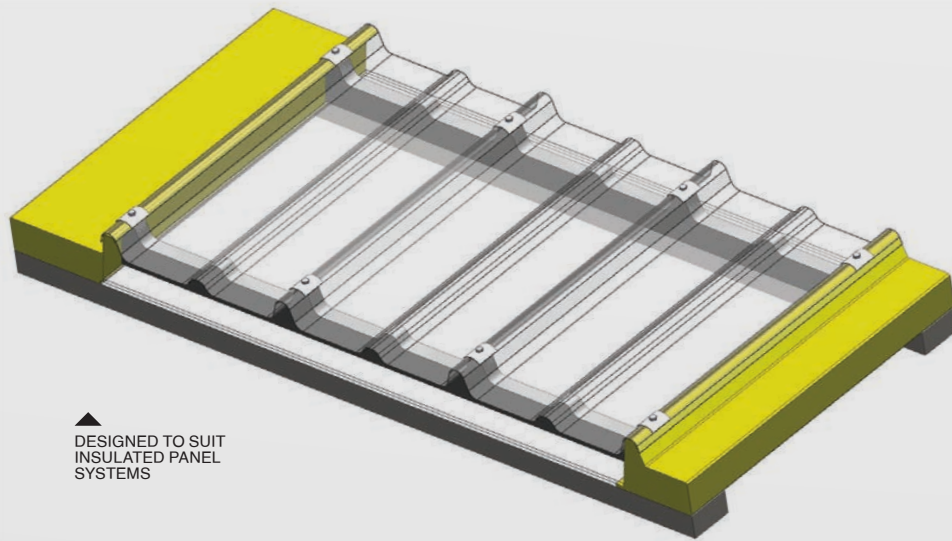

Introduction

Topglass® Triple Skin Systems are primarily designed as a fully insulated natural lighting roofing product. Topglass® GC Ultra-Safe is utilised as a weather surface sheet and one sheet of 10mm Laserlite® Multiwall form the bottom layers. Offering increased thermal and acoustical properties, these systems are utilised in conjunction with insulated panel products.

Key Benefits

- Manufactured from an acrylic modified resin system reinforced with high quality glass rovings, with the incorporation of a reinforced woven roving matrix and Laserlite® Multiwall
- Increased thermal resistance and increased acoustical properties
- Eliminates condensation in most applications
- Manufactured and supplied to match insulated panel systems

Applications

Compliments commercial buildings that require insulated roofing panel construction, and provides natural lighting with the added benefit of offering good thermal resistance.

Surface Coatings

Topglass® GC is the preferred choice for Triple Skin Systems for the external weather surface. Laserlite Building Products 100 micron* EXO-SET 206 Gelcoat weather surface offers very good protection from solar deterioration. Triple Skin Systems can be supplied in most weights g/m² but Topglass® GC Ultra-Safe is recommended for this system.

Colours and Tints

Triple Skin Systems can be supplied in a variety of tints but generally is supplied as translucent clear.

Operating Temperature

Triple Skin Systems operating temperature is -30°C to +70°C

Safety

Topglass® Triple Skin Systems supplied as Topglass® GC Ultra-Safe is classified as heavy-duty, meets the impact test of AS 4040, satisfying the requirements of AS 4256.3 and can support foot traffic, long term degradation and or post roof installation impact damage can seriously affect the performance of the sheeting.

In order to comply with the requirements of AS 1562.3 2006 part 3 plastic, protect the weather surface coating and provide continual structural strength, all GRP products should be protected from foot traffic, therefore a suitable proprietary aluminium walkway is always recommended.

Specification

The translucent sheeting shall be Topglass® GC Ultra-Safe, Triple Skin System 3660 g/m² (unless specified otherwise) manufactured to comply with AS 4256.3 JAZ-ANZ certification licence no. 2349.

The sheeting shall conform with the nominated roofing and cladding profile and be installed in accordance with the requirements of the Laserlite Building Products Topglass® Ultra-Safe proprietary safety fixing system.

Load Span Capabilities

Grade	2400g/m ²	3050g/m ²	3660g/m ²
Sheet thickness	1.5mm	2.0mm	2.5mm
Profile (to match)			
Corrugated / Custom Orb	1.200	1.500	1.600
5 Rib / Trimdek / Trimclad / Monoclad	1.500	1.700	1.900
Speedek 700 / Kliplok 700 / Metlok 700	1.400	1.700	1.900
Prodek / Capacity Plus 660 / Spanrib	1.700	2.100	2.400
Spandek 700 / Longspan 700 / Metrospan 700	1.700	2.100	2.400
Speedek 500 / Metlok 500	1.400	1.700	1.900

Laserlite Building Products has utilised the NZMRM Test bed facility to test industrial roof profiles in excess of 2.0kPa UDL. Product spanning can be increased by increasing the weight (thickness) of the sheet. Based on 1kPa UDL the information contained in the chart is relative to intermediate Purlins, where the sheeting is in single runs and is to be supported by the main roofing and cladding at each side lap. It is important that Purlin spacing be reduced for curved structures, and Laserlite Building Products should be consulted for specific design criteria.

(s) Denotes standard translucent roof sheet weight ex stock. For all other profiles and weights contact Laserlite Building Products.

Profiles

All Topglass® products are available to match common roof profiles, subject to minimum quantity order and raw material availability.

Colour Variation

Due to variations in raw materials shade variations can occur between manufacturing batches.

Weight/Thickness of Sheeting

Laserlite Building Products GRP roofing products can be manufactured in varying thicknesses: Roof profiles: 2400g/m² (1.5mm) – 3660g/m² (2.5mm)

Sheet Lengths

As Topglass® products all roofing profiles can be cut to length.

Design Considerations

Metal roofing profile height is an important design consideration where GRP natural lighting will be installed in conjunction with long lengths of metal roofing. Very low roof pitches (5 degrees or less) combined with low profile metal roofing risk water ingress. Laserlite Building Products recommends in this instance roofing profiles with at least a minimum of 32mm should be utilised in these applications.

Please consult Laserlite Building Products where wind loads exceed 1.5 kPa (kilopascal) for recommended spanning information.

Product Handling and Storage Instructions for all products

- Store sheeting in a dry location and protect from possible wind damage prior to installation.
- Sheeting should not be dragged across objects or other products as it may affect the performance and aesthetics of the roof sheet.
- Care should be taken when loading the translucent roofing onto the roof to avoid bending or distortion of the sheet.
- Sheeting that becomes wet in bundles and is required to be stored should be separated and dried prior to storage.

Recommended Installation Guidelines

- Sheeting may be cut using an abrasive disc or fine tooth saw (use protective gloves and approved face mask).
- GRP Translucent roofing is not designed to support foot traffic and unless specifically excluded in AS 1562.3:2006, clause 2.4.3 requires the use of safety mesh under all translucent roof sheeting. Refer to Figure 5.
- Laserlite Building Products Purlin barrier strip must be installed between the translucent roof sheeting and the safety mesh at the purlin line. Refer to Figure 5.
- Ensure the purlins are correctly spaced and that they are in line.
- GRP fibreglass roofing should always be installed over the main roof cladding at both lapping edges. Refer to Figure 1
- Ensure the weight/thickness of the sheet combined with the selected roofing profile will meet the spanning requirements. Contact Laserlite Building Products for specific design advice.
- Ensure that the correct weathering surface of the sheeting is uppermost as the durability and any warranty is dependent on placing the sheet the correct side up.

- Where two translucent roof sheets are laid side by side, the mid span support shall extend under the metal roofing sheet by a minimum 400mm with fastening through at least two ribs of the metal roofing on either side of the GRP sheet.
- Mid span supports shall not be used where more than two translucent sheets are adjacent to one another.
- If more than two sheets of Topglass® roofing products are to be used side by side, contact Laserlite Building Products for specific guidelines.
- Where roof installations require Topglass® to be laid side-by-side, it is recommended that the use of Lap Seal Tape be

Figure 2

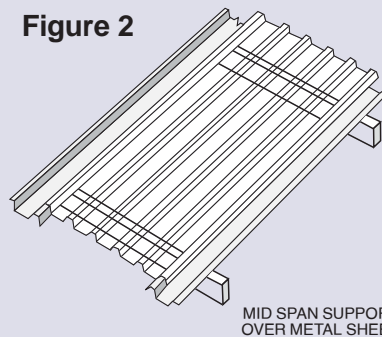

implemented in these situations, therefore preventing possible water ingress over the laps

Stop Ends

Install stop ends to the top of the translucent sheeting as follows.

Use a right-angled folded flashing to the full height of the corrugation or rib, fixed with rivets andalant.

- Severe conditions: Use 0.9mm aluminium.
- Moderate conditions: Use pre-painted metal.

Figure 1 - Laserlite Building Products recommends the use of a strip of 24mm x 5mm Lap Seal Tape

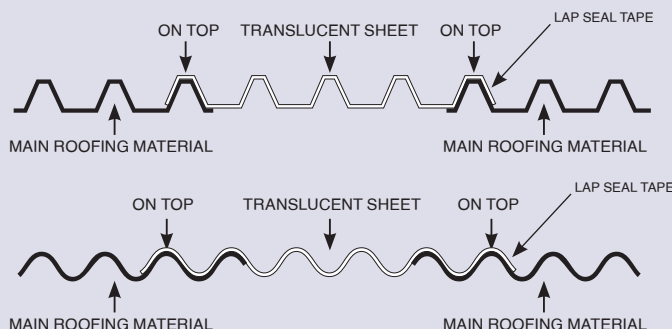

Method 1

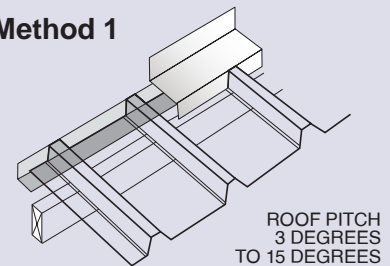

Note: This can also be used in an exposed site, high or very high wind zone for steeper pitched roofs.

Use Laserlite Building Products approved closed cell profiled foam strip fitted close to the screw fixing points.

Sealants

The use of silicone should be minimised as the sealant restricts the ability of the sheet to expand and contract. The use of sealants under side laps is not recommended. In some particular building designs i.e. curved roofing and where the pitch may fall below

Method 2

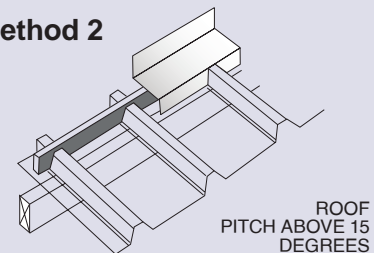

the recommended minimum pitch, Laserlite Building Products Lap Seal Tape can be applied to lapping edges. Expansion and contraction of dissimilar roofing materials should be taken into prior consideration.

Rainwater Gutters

GRP roof sheeting should not be drained into unpainted or galvanised gutters.

Side Lap Fixing

Side laps should be fixed at a maximum spacing of 600mm to prevent wind uplift and leakage, and these fixings shall be through the top of the rib.

End Laps

- The minimum recommended length of end lap of GRP sheets and/or with metal profile sheeting is 200mm.
- Position of lap over purlin - it is recommended the bottom end of the lap sheet be within 50mm of the lower side of the purlin.
- Position of the seal - the bottom bead should be within 25mm from the bottom of the top sheet in lap, and the top bead of seal within 50mm of the top of the bottom sheet.

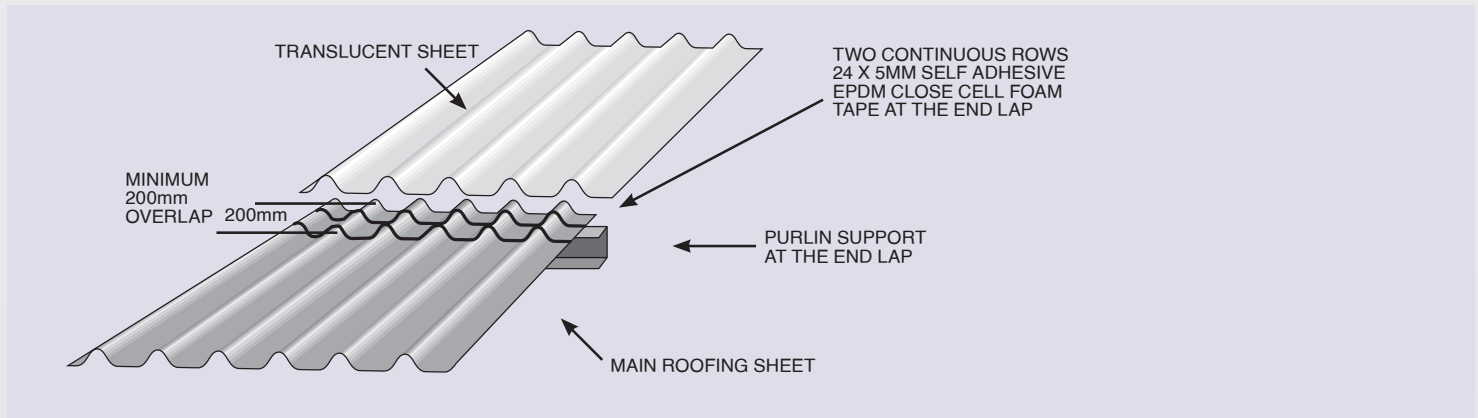

Fastener and Sealing Washer Recommendations

The fastener shall be as for the main roof cladding and will be used in conjunction with a Laserlite Building Products approved load spreading washer constructed of 0.95mm unpainted/pre-painted metal or 1.2mm aluminium to match the main cladding material. In a highly corrosive environment, consideration should be given to the use of stainless steel or other appropriate corrosive resistant material.

Inserted under the load spreading washer will be a 36mm EPDM sealing washer which is to be correctly seated to provide an effective seal. Fasteners should be inserted through the top centre of the rib/corrugation.

Other fastener methods such as 32mm Weatherlock washers maybe suitable based on sheet length and load characteristics. Laserlite Building Products should be contacted for further clarification and advice.

Laserlite Building Products recommends the use of Fibreglass Teks or StoreMate fasteners which drill an oversize hole as they fix.

Oversize screw holes from 10mm up to 15mm must be drilled at all points of fixing. Only 32mm 'Weatherlok' seals should be used.

Note: Where wind loads exceed 1.5kPa, contact Laserlite Building Products for specific design advice. Do not overdrive the fasteners so that deformation of the sheet occurs.

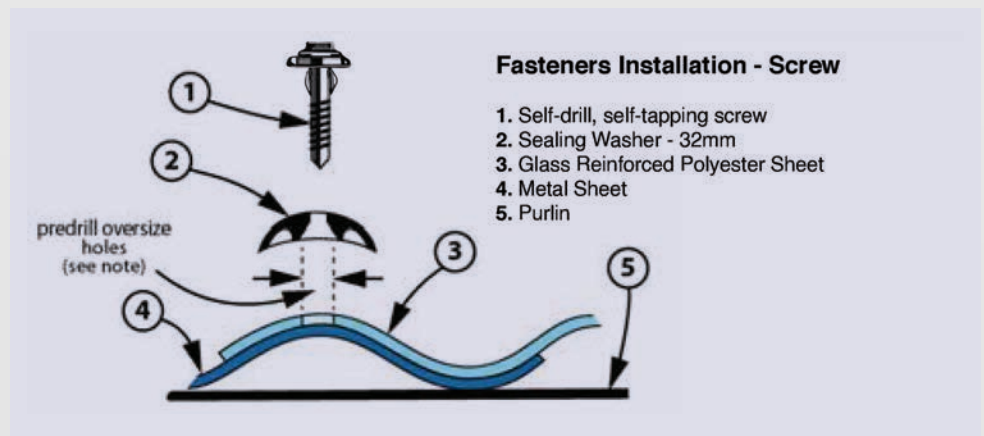

Fastener Pattern

- Corrugated profile end supports and end laps: Fix side laps and every second corrugation.
- Corrugated profile internal supports or purlins: Fix side laps and every third corrugation.
- 5 rib low trapezoidal profiles (19mm to 30mm): On all purlins fix every rib.
- High trapezoidal profiles (50mm to 120mm): On all purlins fix every rib.
- 7 to 8 rib medium trapezoidal profiles (33mm to 49mm) end support and end laps: Fix every rib.
- 7 to 8 rib medium trapezoidal profiles (33mm to 49mm) internal support or purlins: Fix side laps and every second rib.
- Deck profiles - fix every rib.

Further Technical Assistance

The installation instructions are a guide to assist with installation of translucent roof sheeting. For non-standard building design such as draped curve roofs, contact Laserlite Building Products for technical advice prior to ordering product or commencing the project.

PANEL TESTING

TOPGLASS® FIBREGLASS

TESTS AND STANDARDS			
Component Test	Test Standard	Component Test	Test Standard
Impact Resistance	AS/NZS 4257.6:1994	Specific Gravity	ASTM D792-08
Shear Strength	ASTM D732-10	Tensile Strength	ISO 527-1 & ISO 527-2
Compressive Strength	ISO 604-2003	Coefficient of Linear Expansion	ASTM D696-98
Flexural Strength	ASTM D790-10	Thermal Conductivity	C518-10
IMPACT STRENGTH			
Parameter	Test	Value	
	AS/NZ 4256.3	2400gsm	3660gsm
Mass (kg)		0.223	0.223
Drop Height (m)		0.905	0.905
Gravity (m/s)		9.81	9.81
E Impact (J)		1.98	1.98
No. of Samples Tested		40	40
No. of Failed Samples		0	0
GENERAL			
	Test	Value	
		2400gsm	3660gsm
Specific Gravity	ASTM D792-08	1.43	1.44

E=mass x height x gravitational acceleration

MECHANICAL

	Test	Value	
		2400gsm	3660gsm
Flexural Strength Modulus (MPa)	ASTM D792-08	7822	7730
Flexural Strength (MPa)	ASTM D792-08	223	289
Tensile Strength at Maximum Load (MPa)	ISO 527-1 & ISO 527-2	21.9	137
Tensile Strain at Yield (%)	ISO 527-1 & ISO 527-2	1.10	1.93
Shear Strength (MPa)	ASTM D732-10	77.8	81.3
Compressive Strength (MPa)	ISO 604-2003	124	166

THERMAL

	Test	Value	
		2400gsm	3660gsm
Thermal Conductivity K Value Btu-in/hr-ft2-°F	ASTM C518-10	0.249802	0.357473
Thermal Conductivity K Value W/m-K	ASTM C518-10	0.3603	0.05456
Thermal Resistance R Value Hr-ft2-°F	ASTM C518-10	0.24711	0.37564
Thermal Resistance R Value m2-K/W	ASTM C518-10	0.0435	0.0662
Thermal Resistance R/in Hr-ft2-°F/Btu/in	ASTM C518-10	4.01	2.80
Thermal Resistance R/m m2-K/W/m	ASTM C518-10	27.77	19.39
Thermal Resistance U W/m2-K	ASTM C518-10	22.98	15.12

COEFFICIENT OF LINEAR EXPANSION

	Test	Value	
		2400gsm	3660gsm
Coefficient of Linear Thermal Expansion (X10-6mm/mm °C)	ASTM D792-08	29.1	32.6

contact us!

Brisbane

P 07 3208 8277

E OrdersBrisbane@laserlite.com.au

Melbourne

P 03 8393 8054

E OrdersMelbourne@laserlite.com.au

Hobart

P 03 6288 6000

E OrdersHobart@laserlite.com.au

Newcastle

P 02 4940 8922

E OrdersNewcastle@laserlite.com.au

Adelaide

P 08 8444 9666

E OrdersAdelaide@laserlite.com.au

Sydney

P 02 9677 9900

E OrdersSydney@laserlite.com.au

Perth

P 08 9240 6655

E OrdersPerth@laserlite.com.au